

Art. 1104
~50Hz 230V 3,5W G9 LED

Art. 1106
~50Hz 230V 12W E27 LED
~50Hz 230V 15W E27 LED

Art. 1107
~50Hz 230V 12W E27 LED
~50Hz 230V 15W E27 LED

Art. 1108
~50Hz 230V 12W E27 LED
~50Hz 230V 15W E27 LED



EGOLUCE s.r.l. - via I. Newton, 12 - 20016 Pero, Milano - Italy
Tel. +39 02339586.1 - Fax +39 023535112 - www.egoluce.com info@egoluce.com

Optional



0532.31
Elemento per decentramento cromato lucido
Displacement component chromed

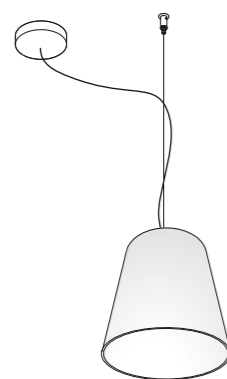

Solo l'uso corretto delle istruzioni garantisce la sicurezza dell'apparecchio:

E' NECESSARIO CONSERVARLE

Disinserire la tensione prima di ogni intervento sull'apparecchio. Per un corretto montaggio vedere lo schema allegato. In caso di sostituzione utilizzare una lampadina di uguale tensione e potenza dell'originale (come da targhetta). Se il cavo è danneggiato esso deve essere sostituito esclusivamente presso Egoluce o a cura del suo servizio di assistenza.

This equipment is guaranteed only if used as indicated in these instructions:

PRESERVE THIS INSTRUCTIONS

Before any operation on this equipment, disconnect the power supply. For a correct assembling see the here enclosed diagram. When replacing, use bulbs with identical voltage and power (check rating plate). If the cable is damaged it must be replaced by Egoluce or by its assistance service.

La sécurité de l'appareil n'est garantie que par le respect des instructions suivantes.

IL EST NECESSAIRE LES CONSERVER

Disjoindre le courant de reseau avant tout operation sur l'appareil. Pour le montage suivre le schéma ici-joint. En case de remplacement, utiliser une ampoule ayant la même tension et puissance que l'originale (c.f. Plaque). Si le cable est dégradé doit être remplacé exclusivement par Egoluce ou par son service assistance.

Nur bei Befolgung der nachfolgenden Anweisungen, ist die Sicherheit des Gerats gewährleistet.

AUFBEWAHREN SIE BITTE DIE ANWEISUNGEN

Abschalten die Netzspannung vor Ausweshsen der lampe. Fur eine einwaldfrei Montage siehe Beigefutges. Bei Lampenersatz, darauf achten, daß Spannung und Sträke die der Originallampe sind (s. Typenschild). Sollte die Zuleitung fehlerhaft sein, so muß sie von Egoluce oder einem anerkannten Fachbetrieb erneuert werden.

Solamente el correcto cumplimiento de las instrucciones puede garantizar la seguridad del aparato:

ES NECESARIO CUMPLIRLAS.

Desconectar la tensión antes de cualquiera intervención en el aparato. Para un ensamblaje correcto, consultar el esquema adjunto. En caso de sustitución, utilizar una lámpara de igual tensión y potencia a la original (referenciada en la etiqueta). Si el cable es dañado, tiene que ser remplazado solamente por Egoluce o por técnicos de su servicio de asistencia autorizados.



	<p>Questo prodotto non deve essere smaltito come rifiuto municipale misto, effettuare una raccolta separata. This product must not be discarded as the responsibility of the City sanitation department, it must be gathered together separately and discarded. Ce produit ne doit pas être mis avec les ordures municipales, il faut effectuer un ramassage séparé. Dieses Produkt darf nicht als Gemeindekehricht entsorgt werden. Entsorgung muss getrennt erfolgen. Este producto no puede ser desechado como basura municipal mixta, efectuar recogida selectiva.</p>
	<p>Apparecchio adatto ad essere installato su superfici normalmente infiammabili. Appareil pouvant être installé sur des surfaces normalement inflammables. Fixture ready for mounting on normally inflammable surfaces. Apparat, der auf normal entflammbare Oberflächen angebracht werden kann. Aparato idóneo para ser utilizado en superficies normalmente inflamables.</p>

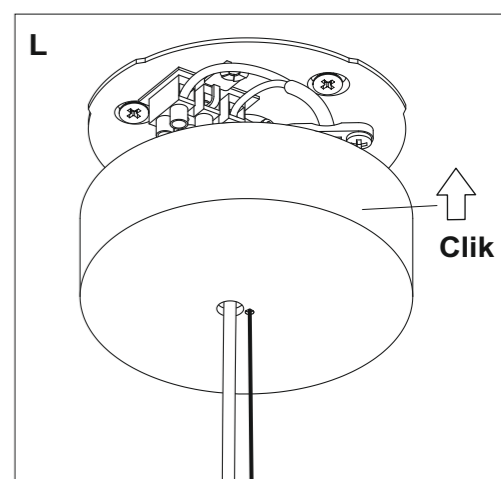
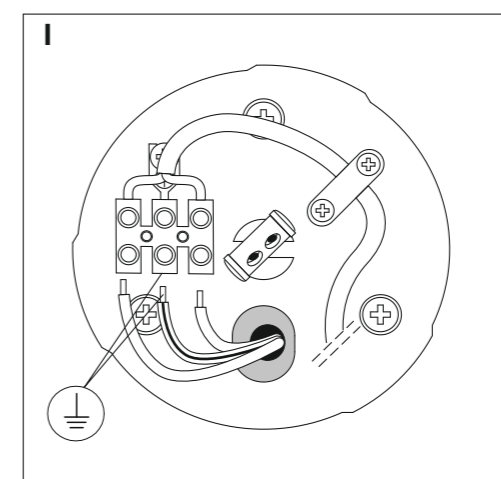
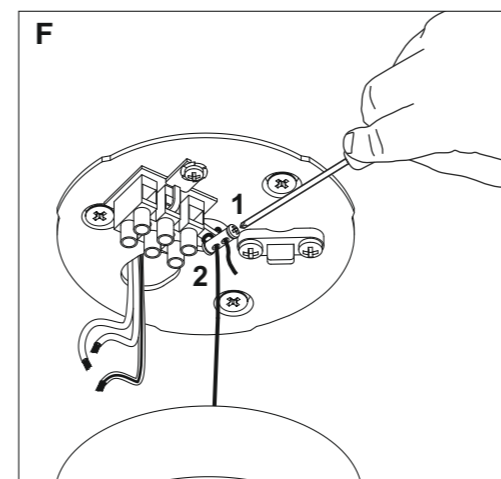
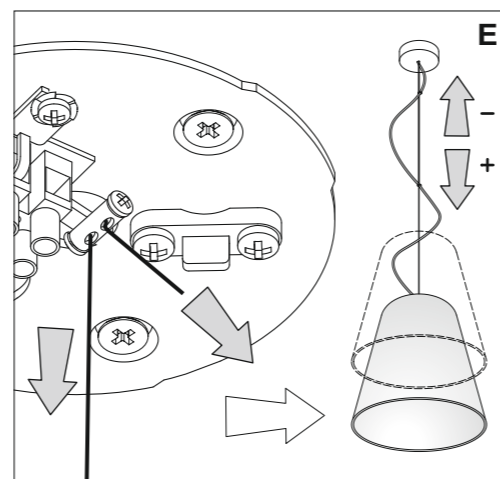
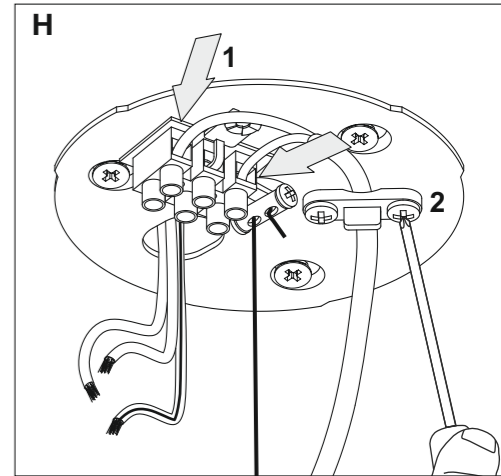
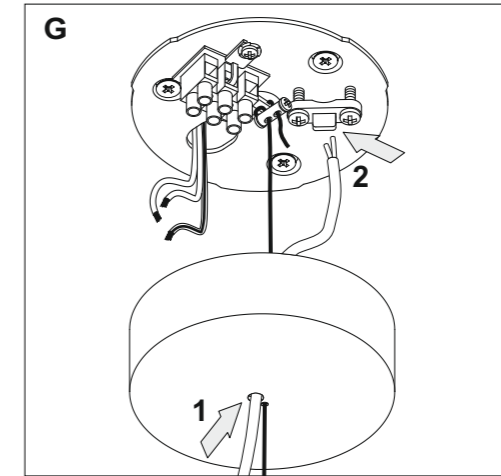
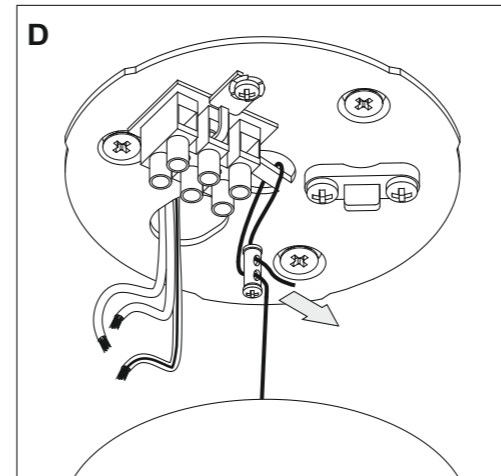
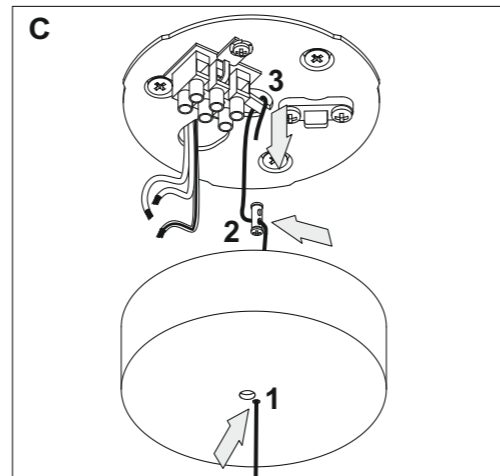
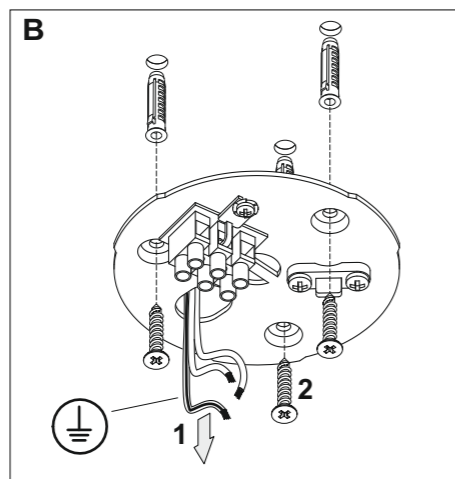
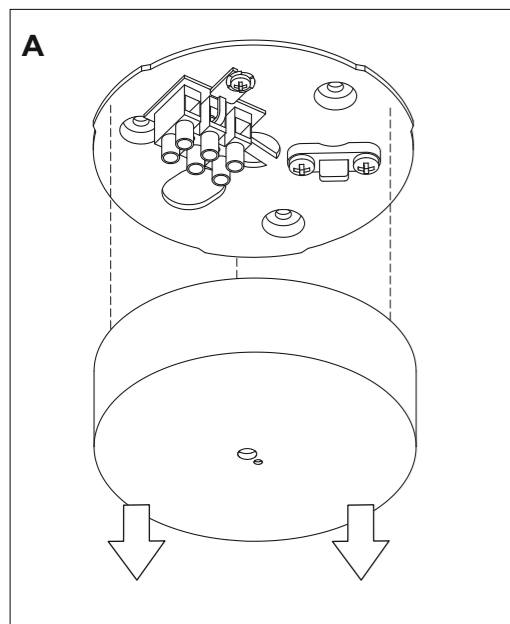
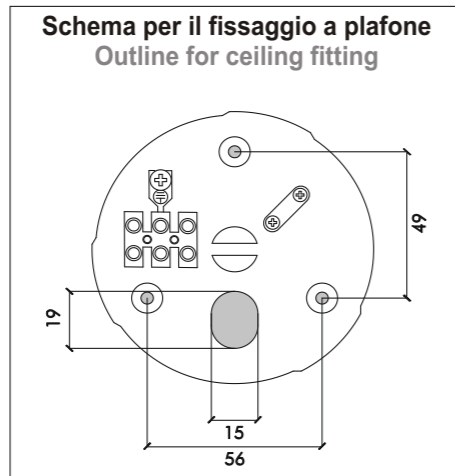
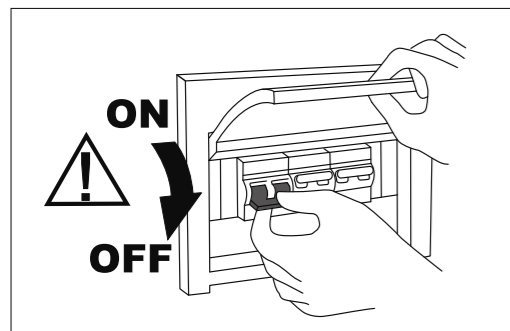

Solo per - Only for: art. 1104

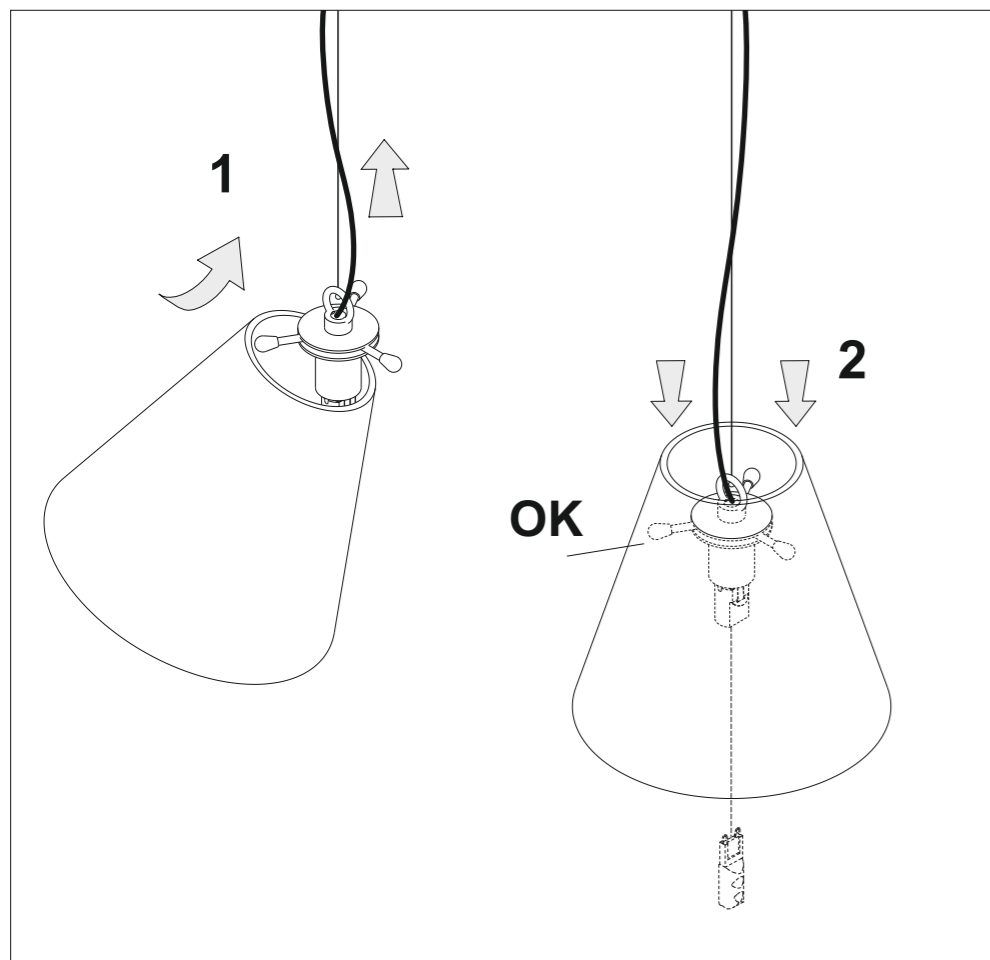

Solo per - Only for: art. 1106 - 1107

