

SPOOK

design U.T EGOLUCE

Solo l'uso corretto delle istruzioni garantisce la sicurezza dell'apparecchio:

E' NECESSARIO CONSERVARLE

L'installazione dev'essere effettuata da installatori qualificati. Disinserire la tensione prima di ogni intervento sull'apparecchio. Per un corretto montaggio vedere lo schema allegato. Non alimentare l'apparecchio con tensione superiore ai 24V. Durante l'installazione non ricoprire l'apparecchio con materiale isolante o similare. E' vivamente sconsigliata l'installazione di interruttori tra alimentatore e led. Gli alimentatori devono essere installati in luoghi areati, lontano da fonti di calore, un eventuale spegnimento dei led dopo qualche ora di funzionamento e la loro successiva riaccensione, indica l'intervento della protezione termica dell'alimentatore e quindi denota che l'installazione non è stata ben fatta (probabilmente, in un ambiente non sufficientemente areato). Se il cavo è danneggiato esso deve essere sostituito esclusivamente presso Egoluce o a cura del suo servizio di assistenza.

Questo prodotto contiene una sorgente luminosa di classe di efficienza energetica F. **EU2019/15**

This equipment is guaranteed only if used as indicated in these instructions:

PRESERVE THIS INSTRUCTIONS

Installation must be made by qualified persons. Before any operation on this equipment, disconnect the power supply. For a correct assembling see the here enclosed diagram. Do not feed light fixture with a voltage higher than 24V. The fitting must not be covered with insulating material during the installation. We advise You against switch installation between converter and led. The led drivers must be necessarily installed in aerated rooms far from heat sources, as well, an eventual switching off of the led system after some working hours and the subsequent switching on again are caused by the intervention of the thermal protection of the driver, due to a possible wrong installation (i.e. in narrow and unaerated rooms). If the cable is damaged it must be replaced by Egoluce or by its assistance service.

This product contains a light source of energy efficiency class F. **EU2019/15**



La sécurité de l'appareil n'est garantie que par le respect des instructions suivantes.

IL EST NÉCESSAIRE LES CONSERVER

L'installation doit être effectuée par des installateurs qualifiés. Disjoindre le courant de réseau avant tout opération sur l'appareil. Pour le montage suivre le schéma ici-joint. Ne pas alimenter l'appareil avec une tension supérieure à 24V. Pendant l'installation ne recouvrir pas l'appareil avec du matériel isolant ou similaire par rapport aux côtes. Ne pas installer un interrupteur entre led et convertisseur. Les convertisseurs doivent être installés dans des endroits aérés et éloignés des sources des chaleur. Une éventuelle extinction des led après quelques heures de fonctionnement, et leurs ré-allumage après quelque temps, indique l'intervention de la protection thermique du convertisseur, ceci est symptomatique d'une installation mal réalisée au mal aérée. Si le cable est damagé doit être remplacé exclusivement par Egoluce ou par son service assistance. Ce produit contient une source lumineuse de classe énergétique F. **EU2019/15**

Nur bei Befolgung der nachfolgenden Anweisungen, ist die Sicherheit des Gerats gewährleistet.

AUFBEWAHREN SIE BITTE DIE ANWEISUNGEN

Der Einbau muss nur von qualifiziertem Installateur ausgeführt werden. Abschalten die Netzspannung vor Ausweshlsen der lampe. Fur eine einwaldfrei Montage siehe Beigefutges. Die den Apparat versorgende Spannung darf 24V nicht überschreiten. Während des Einbau muss das Gerät nicht mit Isoliermaterial abgedeckt werden. den Seiten eingehalten werden. Wir abraten den Schalter zwischen Konverter und Led zu installieren. Die led-Konverter müssen in gelüfteten Stellen weit entfernt von Wärmequellen eingesetzt werden, eine eventuelle Abschaltung des Systems nach einigen Betriebsstunden und seine Wiedereinschaltung erst nachher sind von der Eintretung der thermischen Schutz des Konverters wegen einer falsch ausgeführten Installation verursacht (z.b. in einer enge und unbelüftete Stelle). Sollte die Zuleitung fehlerhaft sein, so muß sie von Egoluce oder einem anerkannten Fachbetrieb erneuert werden.

Dieses Produkt beinhaltet eine Lichtquelle der Energieeffizienzklasse F. **EU2019/15**

Solamente el correcto cumplimiento de las instrucciones puede garantizar la seguridad del aparato:

ES NECESARIO CUMPLIRLAS.

La instalación tiene que ser efectuada por instaladores cualificados. La instalación tiene que ser efectuada por instaladores cualificados. Desconectar la tensión antes de cualquiera intervención en el aparato. Para un ensamblaje correcto, consultar el esquema adjunto. No alimentar el aparato con tensión superior de los 24 volt. En el acto de la instalación no cubrir el aparato con material aislante o similar. No pone un interruptor entre convertidor y led. Los convertidores deben ser instalados en lugares aireados y alejados de fuentes de calor, cuando al cabo de unas horas de funcionamiento se produce el apagados y vuelta a encender de los led se debe a la actuación de la protección térmica del convertidor: esto denota instalación mal hecha o en lugar poco aireado. Si el cable es dañado, tiene que ser remplazado solamente por Egoluce o por técnicos de su servicio de asistencia autorizados.

Este producto incluye una fuente de luz de clase energética F. **EU2019/15**

Dimensioni prodotti - Products dimensions

Cassaforma di partenza completa di tappi e di elemento per estrazione lampada
Starting recessed box with caps and element for lamp maintenance.

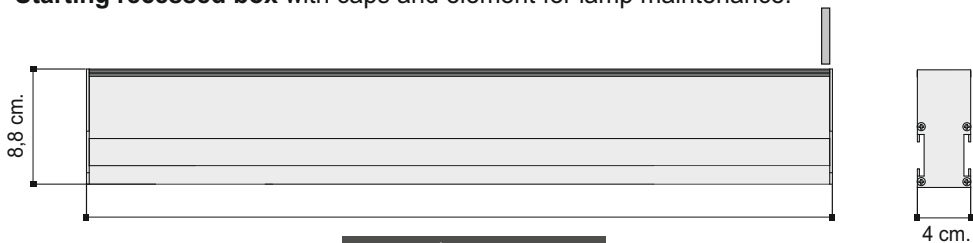

art. 0298/54 - 55,2 cm.
art. 0298/104 - 105,2 cm.
art. 0298/154 - 155,2 cm.
art. 0298/308 - 309,2 cm.

Lunghezza cassaforma di partenza misura speciale = lunghezza apparecchio ordinato + 7mm
Starting recessed box special length = ordered lamp length + 7mm

Cassaforma per continuità' sistema
Recessed box for lamp continuity

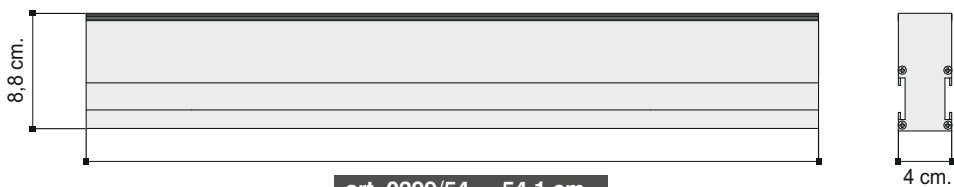

art. 0299/54 - 54,1 cm
art. 0299/104 - 104,1 cm
art. 0299/154 - 154,1 cm
art. 0299/308 - 308,1 cm

Lunghezza cassaforma misura speciale = lunghezza apparecchio ordinato + 1mm
Recessed box special length = ordered lamp length + 1mm

2 giunti per unione cassaforme
2 joint for recessed boxes

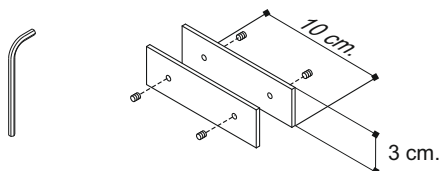

art. 0293/S

2 staffe ancoraggio cassaforma
2 anchor brackets

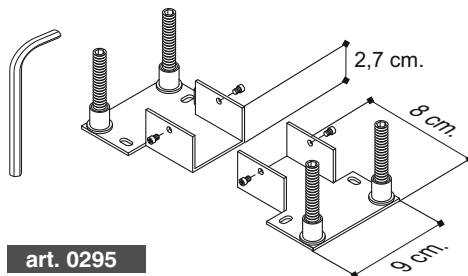

art. 0295

Indicazione generali per l'installazione - Fittings general indications

Predisporre 20-30 cm di ghiaia sotto il pozzetto, poi riempirlo di acqua ed assicurarsi che esca tutta entro 30 min. In caso contrario è obbligatorio un sistema di drenaggio supplementare (fig.2).

Usare solo cavi flessibili in gomma HO5RNF o similari di diametro adatto. NON USARE CAVI RIGIDI e/o CON ANIMA METALLICA (cavi rigidi possono compromettere la tenuta IP67).

Non installare MAI il prodotto in caso di forte umidità, pioggia o nebbia.

Prepare 20-30 cm of drainage gravel and check that it works: fill the tube of water and check that it completely disappear within 30 min.

If it doesn't work study a further drainage system (fig. 2).

Use only HO5RNF or similar flexible cables of suitable diameter. DO NOT USE HARD CABLES OR ARMoured (hard cable could effect the IP67 protection).

Prédisposer toujours 20-30 cm de gravier sous le puits et le remplir d'eau et s'assurer que celle-ci se soit toute écoulee en 30 min. Dans le cas contraire, un drainage supplémentaire est obligatoire (fig. 2).

Utiliser uniquement des câbles souples HO5RNF ou similaires de diamètre apte. NE PAS UTILISER DE CABLES RIGIDES ou ARMES. (Les câbles rigides peuvent compromettre l'étanchéité IP67).

Preparar siempre 20-30 cms de grava de drenaje debajo la hornacina, llenar de agua y comprobar que en 30 min desaparezca. Si no va bien hacer un sistema de drenaje complementario (fig. 2).

Utilizar solo HO5RNF o similares cables flexibles. NO ENTRAR CON CABLES RIGIDOS o BLINDADOS (Cable rígido puede afectar la protección IP67)

Immer 20-30 cm Drainagekies unterhalb des Erdeinbaugeschäuses platzieren und die Funktionstüchtigkeit überprüfen: Das mit Wasser gefüllte Gehäuse muss sich innerhalb von 30 Minuten leeren. Andernfalls ist ein zusätzliches Dränagesystem notwendig (fig. 2).

Nur flexible Gummikabel HO5RNF oder gleichartig verwenden. KEINE STARREN LEITUNGEN VERWENDEN (diese können die Schutzart IP67 beeinträchtigen)

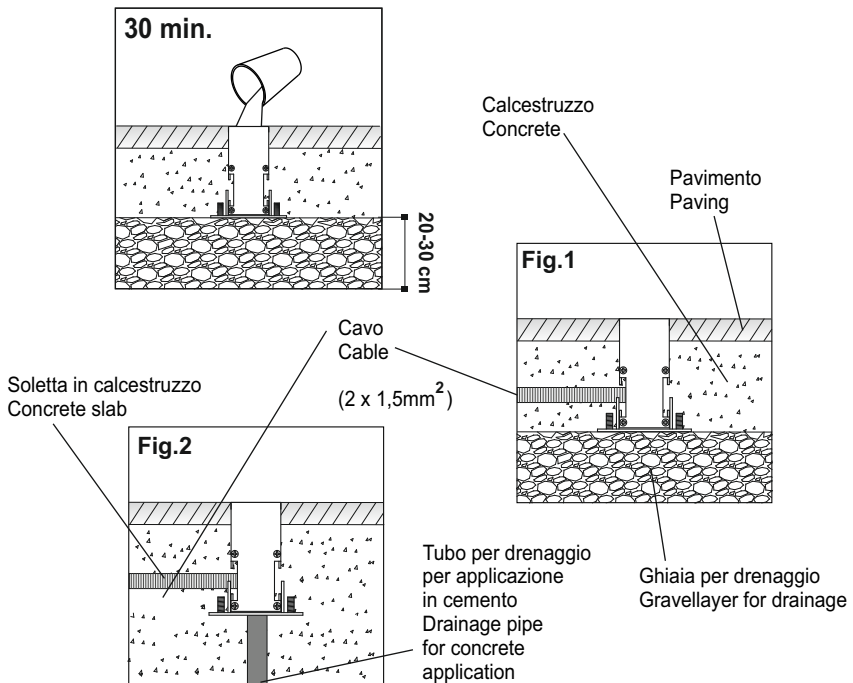

Indicazioni generali cablaggio - Wiring general indications

Effettuare il cablaggio utilizzando il connettore rapido incluso che garantisce il grado di protezione IP 67.
Per tale accessorio usare cavi bipolari con sezione dei cavi 1,5 mm² e diametro 6 mm - 10 mm.

Make the wiring using the supplied fast connector that guaranty the double isolation and the IP 67 degree protection. For this accessory use supply cable bipolar with section 1,5mm² and diameter 6 mm - 10 mm.

Pour le câblage utiliser le connecteur étanche inclus qui assure le degré de protection IP67. Pour cet accessoire utiliser des câbles bipolaires de séction 1,5 mm² et diamètre 6 mm - 10 mms.

Verkabeln mit dem inklusiven Verbinder, der IP 67 versichert. Benutzen Sie bitte dieses Zubehor mit Bipolarem Kabel: Schnitt 1,5 mm² durciamesser 6 mm - 10 mm.

Efectuar el cableado utilizando el connector rapido incluido que garantiza un grado de proteccion IP 67.
Connectar este acesorio utilizando cables de seccion 1,5 mm² y diámetro 6mm - 10 mm.



Per evitare di danneggiare il LED effettuare tutti i collegamenti prima di dare tensione
To avoid damages to LED unit all connection shall be made before to switch power on
Rispettare le polarita' nel collegamento - Respect correct polarity when connecting

Marrone/brown + Blu/blue -

Solo collegamento in parallelo - Only parallel connection

Esclusivement montage en paralléle - Nur fur parallelverbindungConexion en paralelo



Montaggio dell'alimentatore: remoto - Converter mounting: remote - Montage du convertisseur: séparé
Montage des Konverters: extern - Montaje del convertidor: remoto

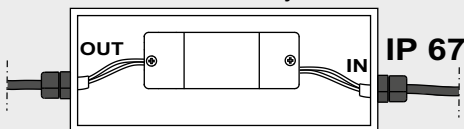

Art.0155 - Alimentatore 24V 13W

Art.0156 - Alimentatore 24V 25W

Art.0160 - Alimentatore 24V 50W

Art.0157 - Alimentatore 24V 70/72W

Art.0162 - Alimentatore 24V 150W

INSTALLAZIONE SINGOLA - Esploso tecnico

SINGLE INSTALLATION - Exploded view

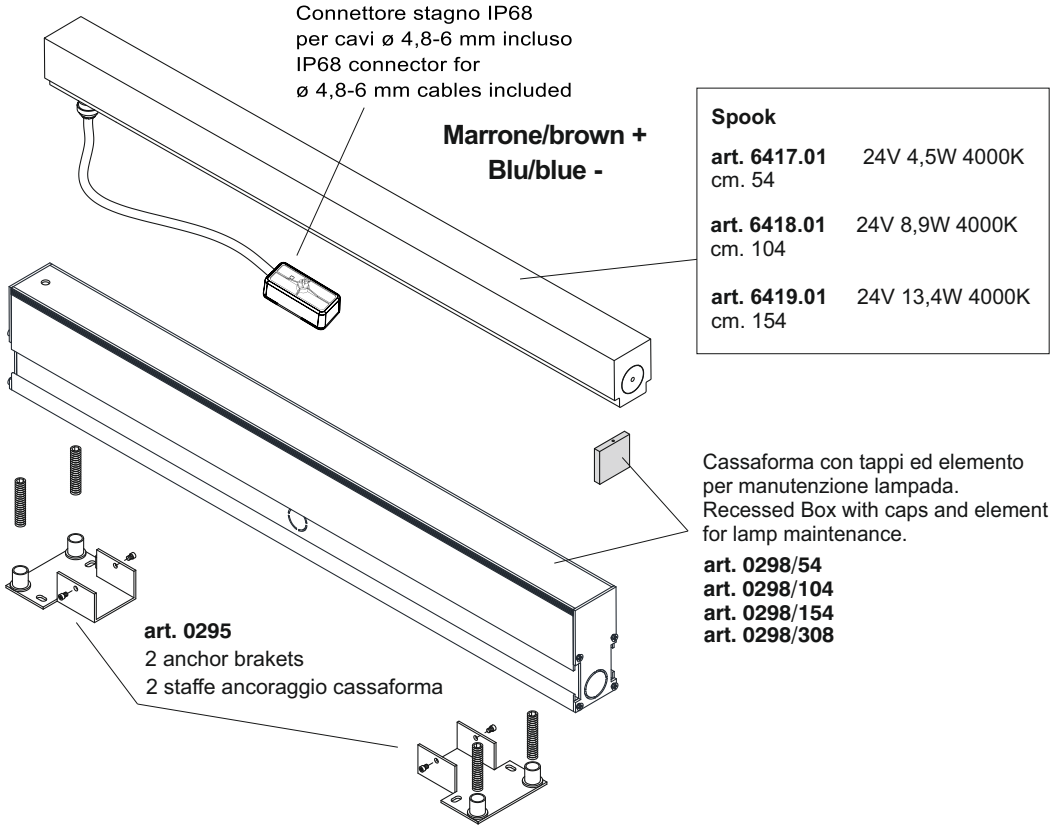

Assemblaggio cassaforma singola

Assembling single recessed box

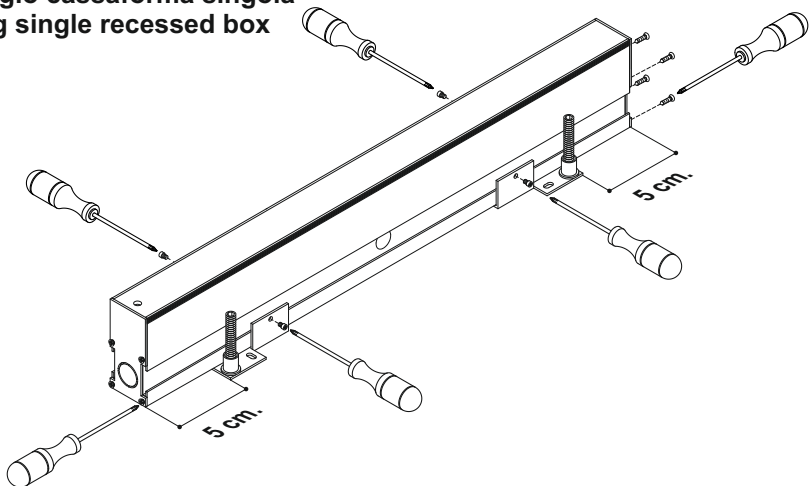

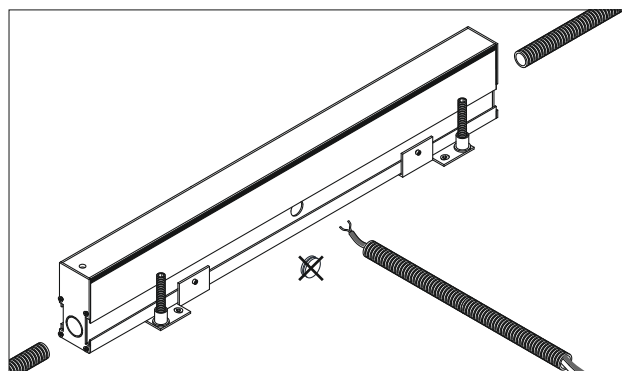
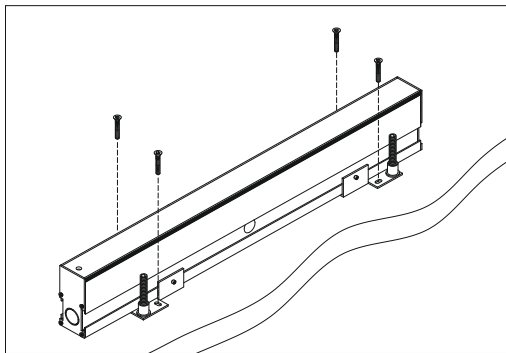
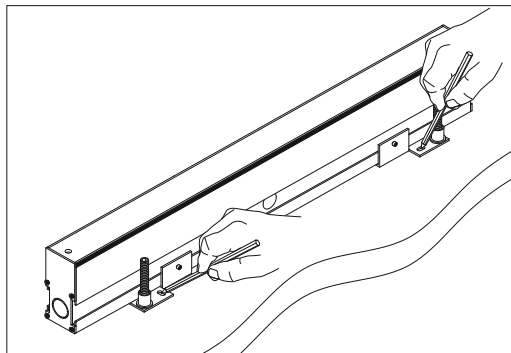
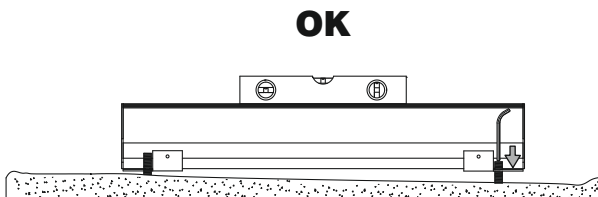
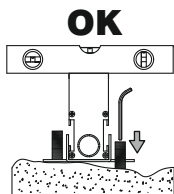
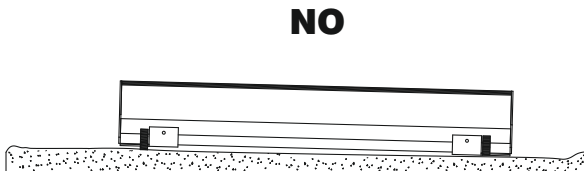
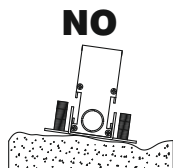
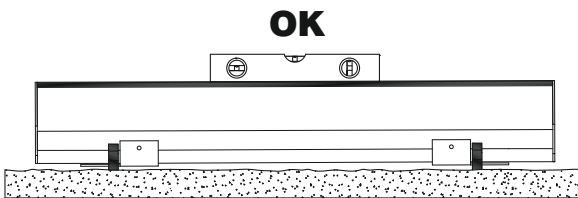
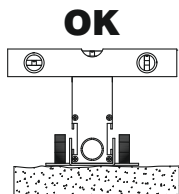

Utilizzare un solo ingresso della cassaforma per ogni singola barra
Non fare collegamenti passanti tra le barre.

Use only one cable inlet per each box.
Do not make interconnections between different boxes.

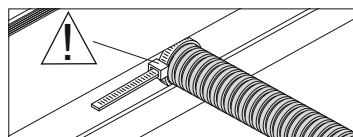

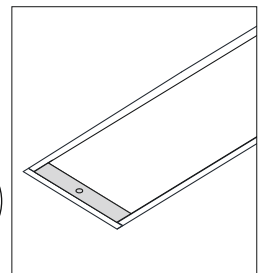
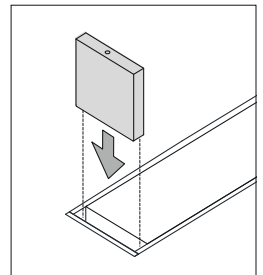
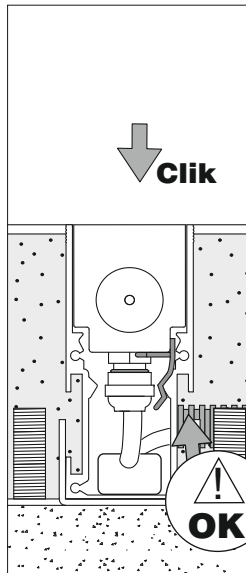
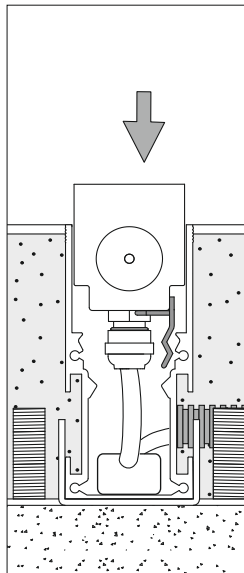
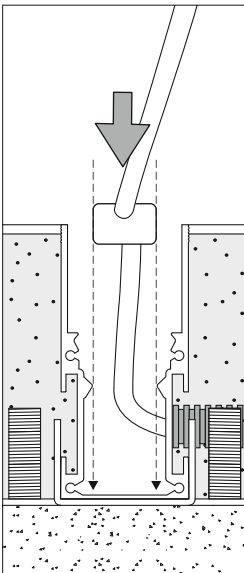
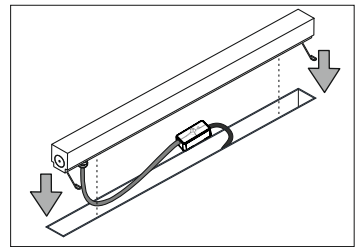
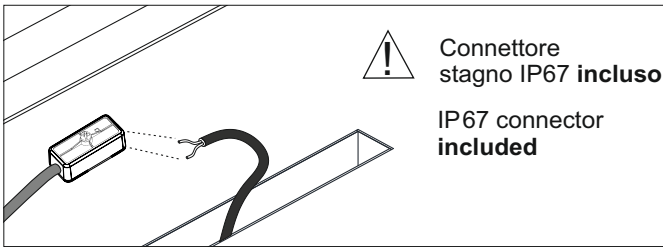
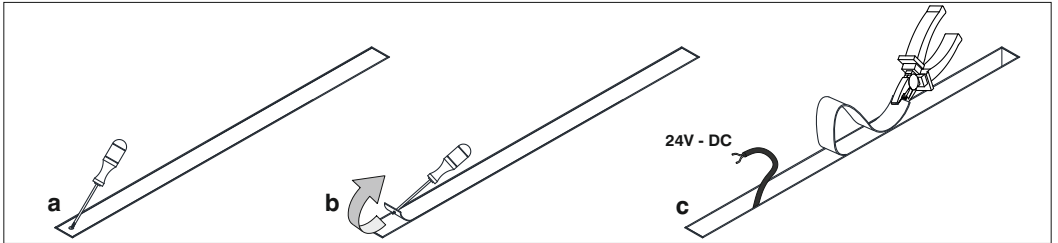
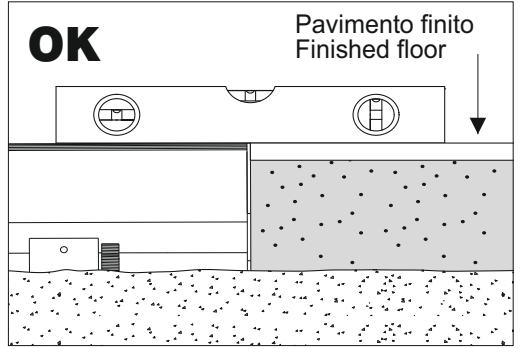
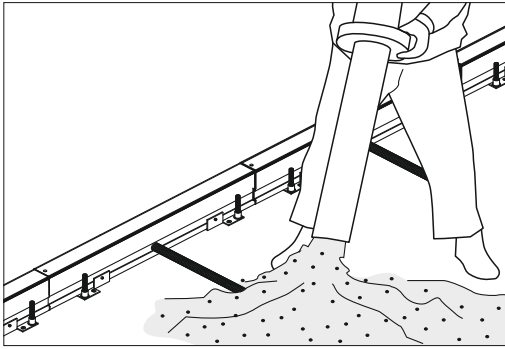

INSTALLAZIONE SISTEMA - Esploso tecnico SYSTEM INSTALLATION - Exploded view

Spook

art. 6417.01	24V 4,5W 4000K	cm. 54
art. 6418.01	24V 8,9W 4000K	cm. 104
art. 6419.01	24V 13,4W 4000K	cm. 154
art. 6417.01/...	- cm. 14 cm. 154	

Marrone/brown + Blu/blue -

Connettore stagno IP68
per cavi \varnothing 4,8-6 mm incluso
IP68 connector for
 \varnothing 4,8-6 mm cables included

2 giunti per unione cassaforme
2 joint for recessed boxes
art. 0293/S

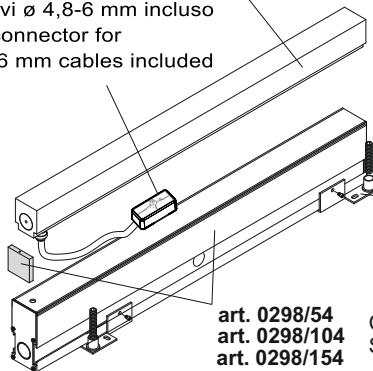

art. 0298/54
art. 0298/104
art. 0298/154
art. 0298/308

Cassaforma di partenza con elemento per manutenzione lampada.
Starting recessed box with element for lamp maintenance.

Cassaforme - Recessed Box
art. 0299/54
art. 0299/104
art. 0299/154
art. 0299/308

art. 0295 2 staffe ancoraggio cassaforma
2 anchor brackets

Assemblaggio cassaforma sistema
Assembling system recessed box

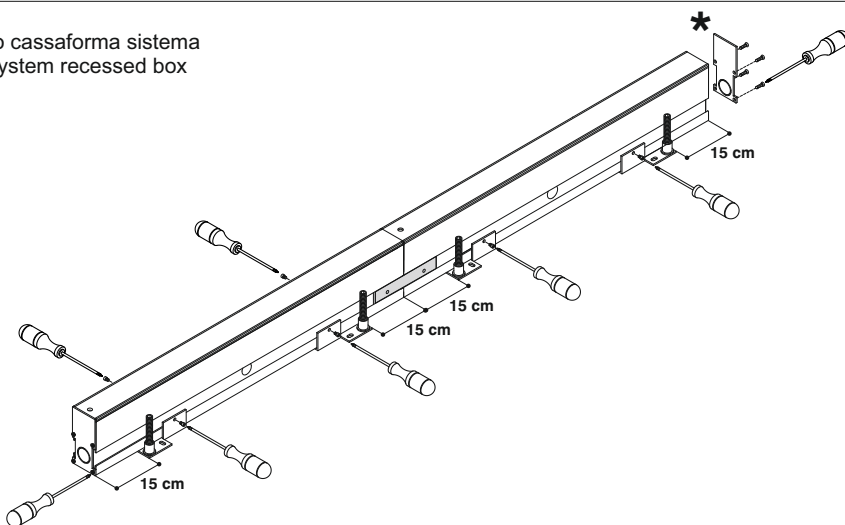

Il tappo di chiusura è fornito con la cassaforma di partenza.
The end stopper is included in the starting box.



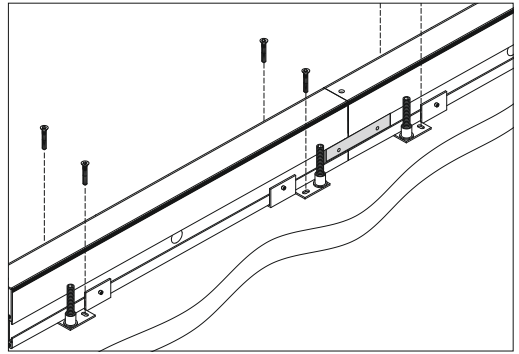
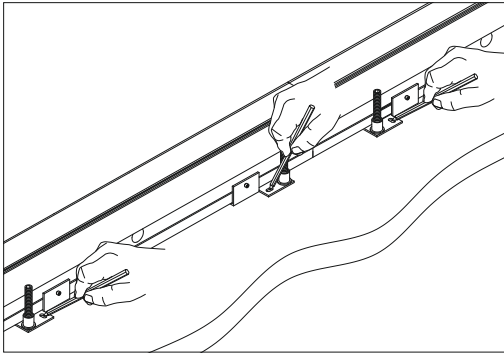
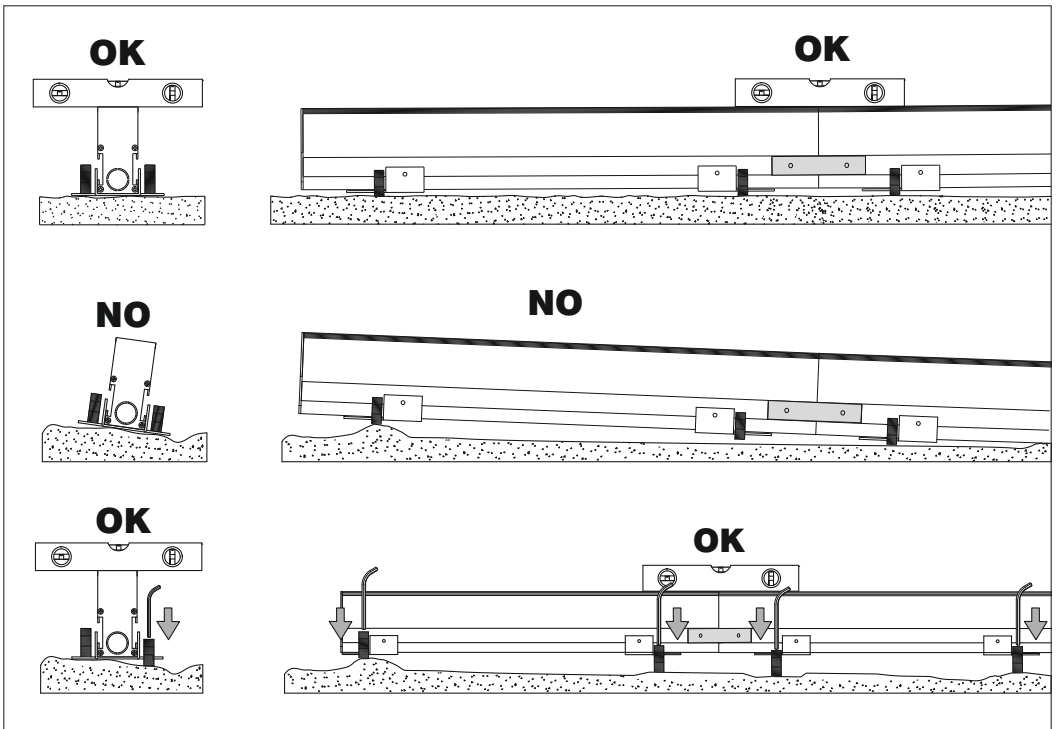

Utilizzare un solo ingresso della cassaforma per ogni singola barra
 Non fare collegamenti passanti tra le barre.

Use only one cable inlet per each box.
 Do not make interconnections between different boxes.

A **B** **C**

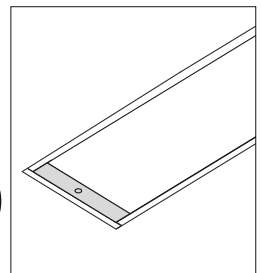
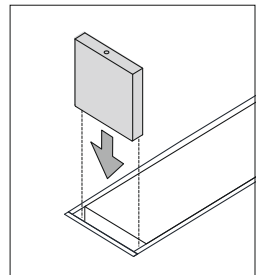
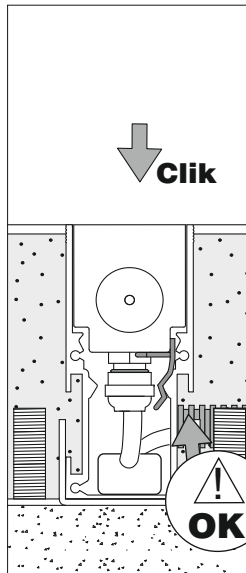
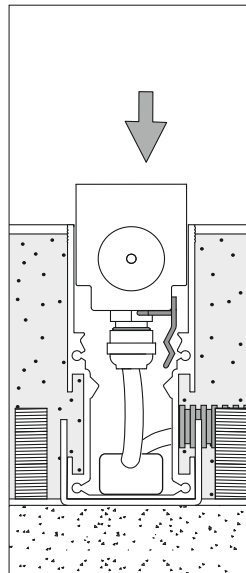
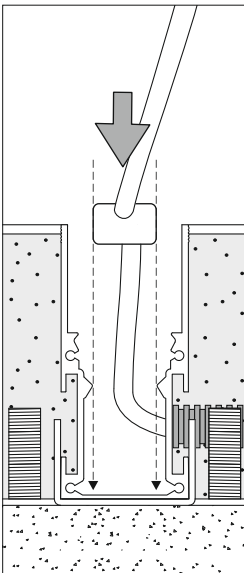
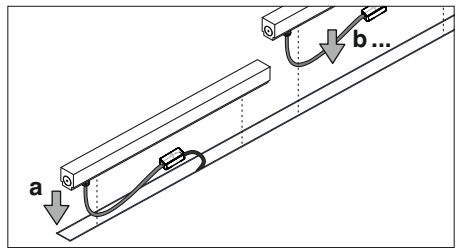
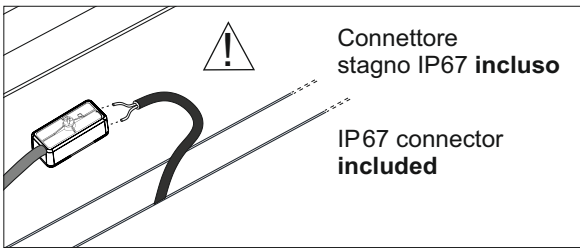
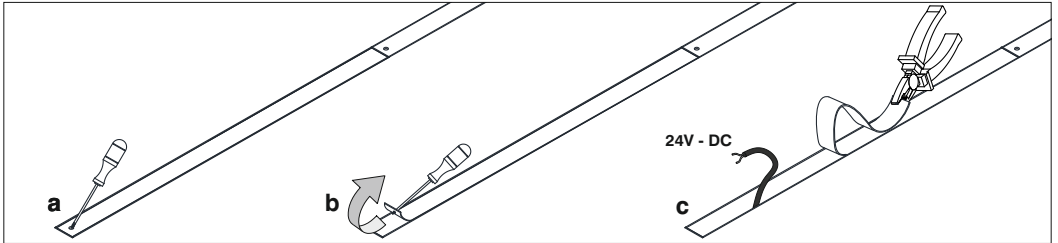
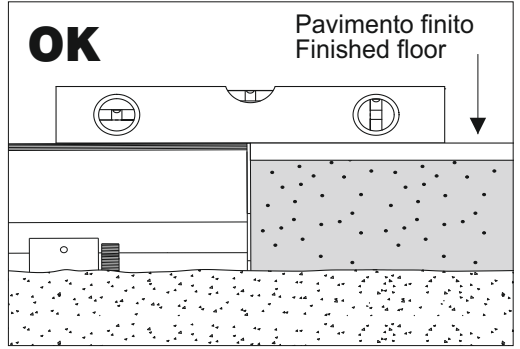
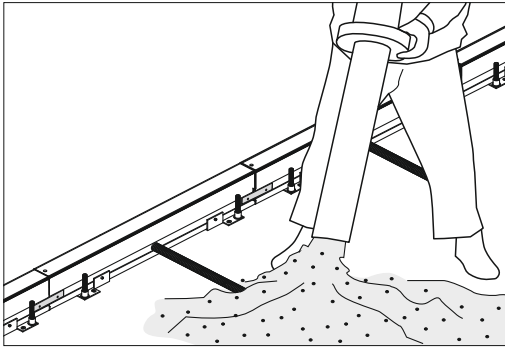

MANUTENZIONE LAMPADA - LAMP MAINTENANCE

ATTENZIONE:

Per la pulizia del diffusore usare esclusivamente acqua e sapone per lo sporco più tenace.

Non usare alcol o altri solventi. NON USARE IDROPULITRICI

WARNING:

To clean the diffuser use only water and soap if needed for resistant dirt.

Do not use alcohol or other solvents. DO NOT USE WATER HIGH PRESSURE CLEANERS

ATTENTION:

Pour le nettoyage de la lampe utiliser exclusivement de l'eau et du savon pour les salissures plus tenaces.

Ne pas utiliser d'alcool ou solvants.

NE UTILISEZ PAS DE NETTOYER HAUTE PRESSION SUR LA LUMINAIRE

ACHTUNG:

Bei der Reinigung der Leuchte darf man ausschließlich mit Wasser und Seife oder mit einem neutren Reinigungsmittel anfeuchten.

Kein Alkohol oder Lösungsmittel verwenden.

HOCHDRUCKREINIGER BENÜTZUNG IST VERBOTEN

QUIDADO:





Para la limpieza del difusor, agua y sabon.

No utilizar alcol o otros solventes.

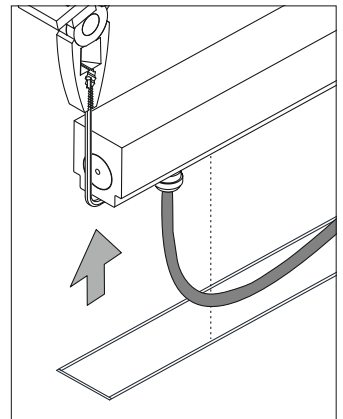
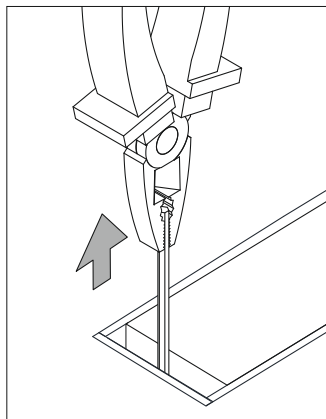
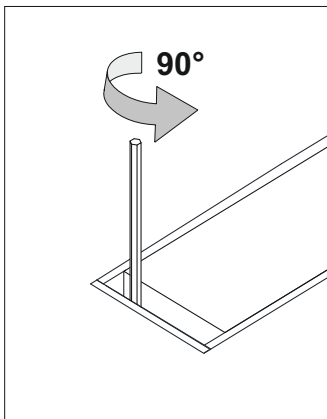
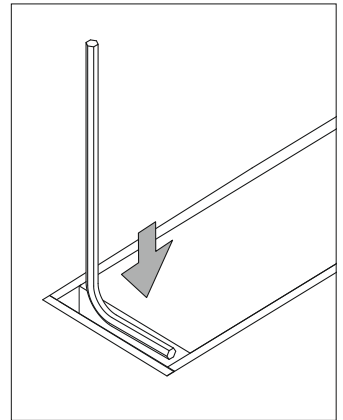
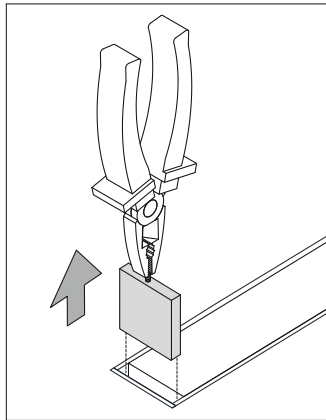
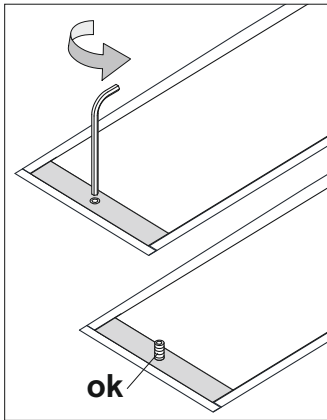
NO UTILISAR LIMPIADORA DE ALTA PRESIÓN

MANUTENZIONE LAMPADA - LAMP MAINTENANCE



	<p>Apparecchio in classe III. Class III luminaire. Appareil de classe. Gerät der Klasse III. Aparato de clase III.</p>
	<p>Apparecchio adatto ad essere installato su superfici normalmente infiammabili. Fixture ready for mounting on normally inflammable surfaces. Appareil pouvant être installé sur des surfaces normalement inflammables. Apparat, der auf normal entflammbare Oberflächen angebracht werden kann. Aparato idóneo para ser utilizado en superficies normalmente inflamables.</p>
<p>IP x7</p>	<p>Protetto contro l'immersione. Watertight immersion luminaire. Étanche pour immersion. Eintauchenwassergeschützt. Estanco para inmersión.</p>
<p>IP 6x</p>	<p>Apparecchio totalmente protetto contro la polvere. Dust-tight luminaire. Protégé totalement contre la poussière. Staubdicht. Protégé totalmente contra el polvo</p>
	<p>Sostituire gli schermi di protezione danneggiati. Replace any cracked protective shield. Remplacer les écran de protection endommagés. Schutzschirm, falls zerbrochen, sofort ersetzen. Reemplazar pantalla de protección dañados</p>
	<p>Gli apparecchi sono stati progettati e collaudati per reggere un carico statico fino a 500 Kg, per installazioni in zone esclusivamente pedonali. The fittings have been designed and tested to withstand a static load of 500 Kg for installation exclusively in pedestrian. Les appareils ont été spécialement conçus et testés pour supporter une charge statique pouvant atteindre 500 Kg, pour l'installation dans des zones seulement piétonnes. Bei der Entwicklung und Prüfung der Leuchten wurde sichergestellt, dass sie einer statischen Belastung von bis zu 500 kg standhalten; damit eignen sie sich ausschließlich zur Installation auf Gehwegen. Los aparatos han sido diseñados y ensayados para resistir una carga estática de 500 Kg, para instalaciones exclusivamente en zonas para peatones.</p>
	<p>La bassa temperatura superficiale (40°C), non crea limitazioni d'installazione. The low surface temperature (40°C) impose no limits on installation. La température de surface réduite (40°C) ne pose aucune limitation d'installation. Dank der niederen Temperatur der Kontaktflächen (40°C) sind bei der Installation keine diesbezüglichen Einschränkungen gegeben. La baja temperatura superficial (40°C) no impone limitaciones de instalación.</p>
<p>IK10</p>	<p>Resistenza meccanica agli urti con un'energia d'impatto di 20J Mechanical resistance with impact energy of 20J Résistance à l'impact avec une énergie d'impact de 20J Schlagfestigkeit mit Aufprallenergie 20J Resistencia a los impactos con una energía de 20 J di'impatto</p>

Simbolo RAEE (Rifiuti Apparecchiature Elettriche ed Elettroniche). Il simbolo RAEE utilizzato per questo prodotto indica che quest'ultimo non può essere trattato come rifiuto domestico. Lo smaltimento corretto di questo prodotto contribuirà a proteggere l'ambiente. Per maggiori informazioni sul riciclaggio di questo prodotto, rivolgersi all'ufficio competente del proprio ente locale, alla società addetta allo smaltimento dei rifiuti domestici o al negozio dove è stato acquistato il prodotto.

RAEE Symbol (Waste Electrical and Electronic Equipment). The use of the RAEE symbol indicates that this product may not be treated as household waste. By ensuring this product is disposed of correctly, you will help protect the environment. For more detailed information about the recycling of this product, please contact your local authority, your household waste disposal service provider or the shop where you purchased the product.



Symbole RAEE (Waste Electrical and Electronic Equipment, Déchets électriques et d'équipement électronique). L'utilisation du symbole RAEE indique que ce produit ne peut pas être traité comme déchet domestique. Assurez-vous de vous débarrasser de ce produit selon les lois en vigueur. Vous aiderez ainsi à protéger l'environnement. Pour plus d'informations détaillées sur le recyclage de ce produit, veuillez contacter les autorités locales, le fournisseur de service de mise au rebut des déchets domestiques ou le magasin où vous avez acheté le produit.

Symbol RAEE (Waste Electrical and Electronic Equipment). Durch Verwendung des RAEE-Symbols weisen wir darauf hin, dass dieses Produkt nicht als normaler Haushaltsmüll behandelt werden darf. Sie tragen zum Schutze der Umwelt bei, indem Sie dieses Produkt korrekt entsorgen. Genauere Informationen zum Recycling dieses Produkts erhalten Sie von Ihrer Stadtverwaltung, von Ihrem Müllabfuhrunternehmen oder im Laden, in dem Sie das Produkt erworben haben.

Simbolo RAEE (Residuos de aparatos eléctricos y electrónicos). El símbolo RAEE en un producto indica que éste no se puede eliminar como cualquier otra basura. Si garantiza la eliminación correcta del producto, ayudará a proteger el medio ambiente. Para obtener más informaciones sobre el reciclaje del mismo, póngase en contacto con las autoridades locales pertinentes, con el proveedor de servicios de recogida de basura o con el establecimiento donde adquirió el producto.

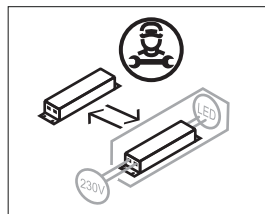
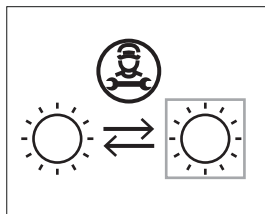



EGOLUCE s.r.l. - via I. Newton, 12 - 20016 Pero, Milano - Italy - Tel. +39 02339586.1 - Fax +39 023535112 -
www.egoluce.com info@egoluce.com